

Submersible Grinder Pump Type ABS Piranha 08 - 110

Submersible pumps for problem-free pumping of sewage containing faecal matter in pipe lines from 1¼" (DN 32).



Applications

Piranha submersible pumps have been designed for effective and economic dewatering using discharge lines of small diameter, in private, municipal and industrial areas.

- Sewage removal from living units and houses in remote settlements where the laying of a conventional sewer would be too expensive, where large ground undulations are present or where it is only possible to lay pipe lines of small diameter.
- Sewage removal from motorway resting sites, communal buildings and for renovation of buildings or areas of a city.
- For use in slaughter houses, food processing plants, paper factories, agriculture and similar areas.
- Piranha 08 and 09 are specially designed for private and domestic applications.
- Maximum allowable temperature of the medium is 40 °C, or short term to 60 °C (max. 5 minutes)



Construction

The water pressure-tight, encapsulated fully flood-proof motor and the pump section form a compact, robust, unit construction.

Bearings

The stainless steel motor shaft is supported in lubricated-for-life ball bearings.

Shaft sealing

Piranha 08 - S26: Between motor and hydraulic section by means of a high quality sealing unit using a silicon carbide mechanical seal. Seal at motor side is by oil lubricated lip seal.

Piranha PE30/2C - 110/2E: Double mechanical seals, SiC-SiC at the hydraulic side, SiC-C at the motor.

All seals are independent of direction of rotation and resistant to temperature shock

Discharge

Piranha 08 and 09: DN 32 flange with G 1¼" internal thread
Piranha S10 - S26 and PE30/2C: DN 32 flange (G 1¼" threaded adaptor available as accessory)

Piranha PE55/2E - PE110/2E: DN 50 with DIN-flange

Shredding system

Spiral bottom plate and stationary cutter ring combined with a shredding rotor located before the impeller, for optimum blockage-free running.

Temperature monitoring

Thermal sensors in the stator to switch off the pump in the case of overheating and switch on automatically after cooling down (optional for non-Ex Piranha-S model).

Seal monitoring

DI system consisting of a sensor in the motor and oil chambers which signals an inspection alert if there is leakage at the shaft seals (not in oil chamber on Ex Piranha-S). Not available for Piranha 08 and 09; optional for non-Ex Piranha-S.

Features

- Unique Piranha shredding system capable of shredding items such as cloths and plastic bags.
- For the pumping of wastewater containing sewage, offal, organic and industrial effluent.
- Piranha 08 and 09 fitted with MF modular motor; Piranha-S with AS, Piranha PE with XFP Premium Efficiency IE3.
- Piranha 08 and 09 available as KS version with float switch.
- Small discharge lines from 1¼" (DN 32).
- Installations are possible where large ground undulations are present.
- Standard and Ex-versions (see motor data below).
- Piranha 08 and 09 have capacitor in upper lid and do not require a control box.
- Low installation costs due to small diameter discharge pipework.

Motor

Three-phase 400 V or single-phase 220-240 V, 50 Hz, 2-pole (2900 r/min) or 4-pole (1450 r/min).

Cooled by amply dimensioned cooling areas.

Piranha 08 & 09: insulation class F, protection type IP 68, non-Ex only.

Piranha S10 - S26: insulation class F, protection type IP 68, Ex and non-Ex.

Piranha PE30/2C - PE110/2E: Premium Efficiency IE3 with NEMA Class A temperature rise, insulation class H, protection type IP 68, Ex only.

Explosive-proof versions are in accordance with EX d IIB T4 and ATEX international standards.

Materials

Description	Material
Upper Lid *	Stainless steel 1.4301 (AISI 304)
Motor Housing	Cast iron EN-GJL-250
Rotor Shaft	Stainless steel 1.4021 (AISI 420)
Volute	Cast iron EN-GJL-250
Impeller **	Cast iron EN-GJL-250
Fasteners	Stainless steel 1.4401 (AISI 316)

* Piranha 08 and 09

** Polyamide for Piranha 08

Technical Data

Piranha W = 1-phase D = 3-phase	Discharge		Motor power ** (kW)		Rated current (A)	Rated voltage (V)	Speed (r/min)	Cable size ***	Weight **** (kg)
	Flange DN	Internal thread *	P ₁	P ₂					
08W	32	G 1¼"	1.41	1.00	6.41	220-240 1~	2900	3G1.0	18
08D	32	G 1¼"	1.34	1.00	2.71	400 3~	2900	4G1.0	18
09W	32	G 1¼"	2.56	1.84	11.60	220-240 1~	2900	3G1.0	23
09D	32	G 1¼"	2.56	2.00	4.64	400 3~	2900	4G1.0	23
S10/4W ^{†1}	32	G 1¼"	1.69	1.00	7.49	220-240 1~	1450	4G1.5	32
S12/2W ^{†1}	32	G 1¼"	1.77	1.20	8.22	220-240 1~	2900	4G1.5	32
S12/2D	32	G 1¼"	1.69	1.20	3.29	400 3~	2900	4G1.5	32
S13/4D	32	G 1¼"	1.93	1.30	3.60	400 3~	1450	4G1.5	32
S17/2W ^{†1}	32	G 1¼"	2.36	1.65	10.60	220-240 1~	2900	4G1.5	32
S17/2D	32	G 1¼"	2.31	1.70	3.97	400 3~	2900	4G1.5	32
S21/2D	32	G 1¼"	2.79	2.10	4.75	400 3~	2900	4G1.5	37
S26/2D	32	G 1¼"	3.43	2.60	5.64	400 3~	2900	4G1.5	40
PE30/2D-C	32	G 1¼"	3.42	3.00	5.58	400 3~	2900	7G1.5	90
PE55/2D-E	50 DIN	-	6.08	5.50	10.30	400 3~	2900	10G1.5	130
PE70/2D-E	50 DIN	-	7.74	7.00	13.50	400 3~	2900	10G1.5	130
PE90/2D-E	50 DIN	-	9.84	9.00	17.00	400 3~	2900	10G1.5	160
PE110/2D-E	50 DIN	-	12.10	11.00	20.10	400 3~	2900	10G1.5	160

* Piranha 08 and 09 flange has internal thread. Piranha S10/4 - S26/4 and Piranha PE30/2D-C has threaded flange adaptor as optional accessory

** P₁ = Power at mains; P₂ = Power at motor shaft

*** Piranha S10/4 Ex and Piranha S10 /4- S26/2 with Di and klixon: 7G1.5 **** Weight with 10 m cable

†1 Start and Run capacitor to the following specification required in control panel.
Start: 125-160µF
Run: 40µF (2x20µF) for S10/4W, 30µF for S12/2W and S17/2W
The recommended start time for the motors is two seconds.

Performance Curves

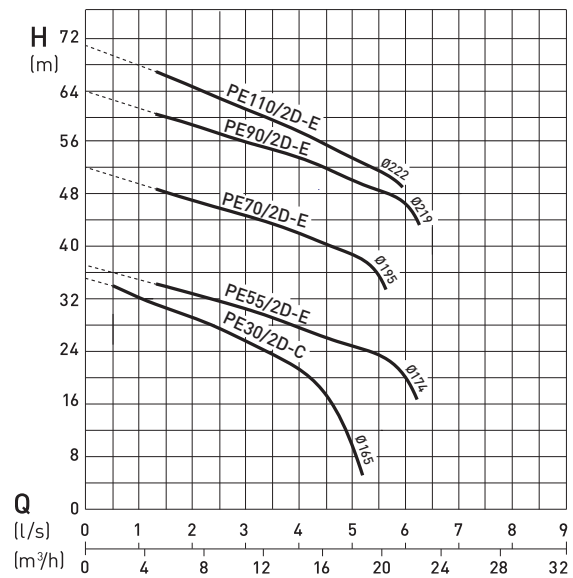
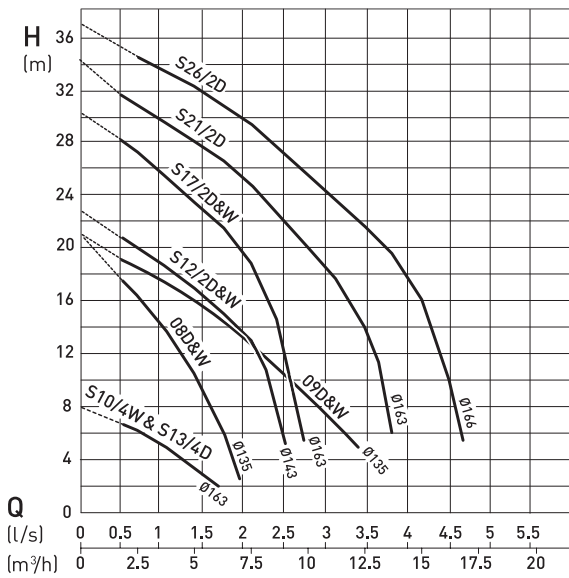

H = Total Head; Q = Discharge Volume. Curves to ISO 9906 (60 Hz available on request) N.B. please use the ABSEL program to validate pump selection.

Dimensions (mm)

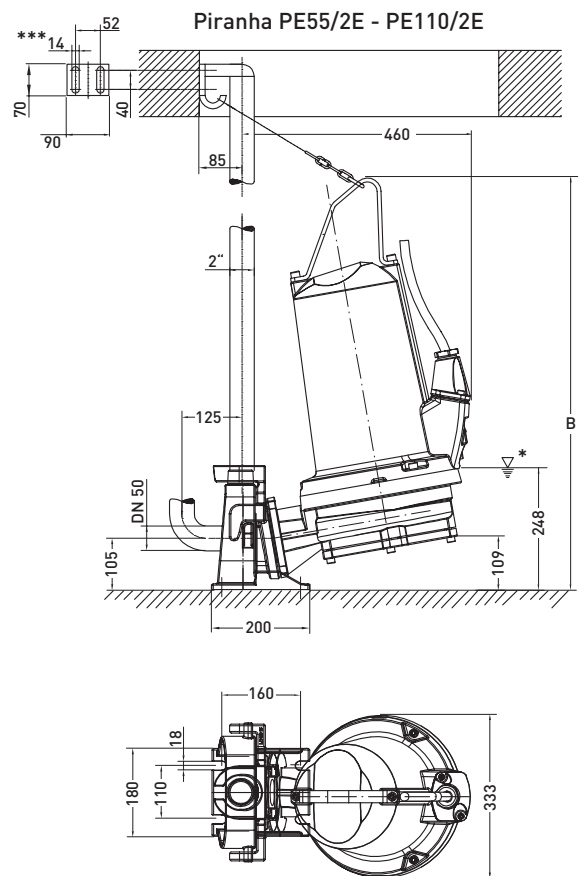
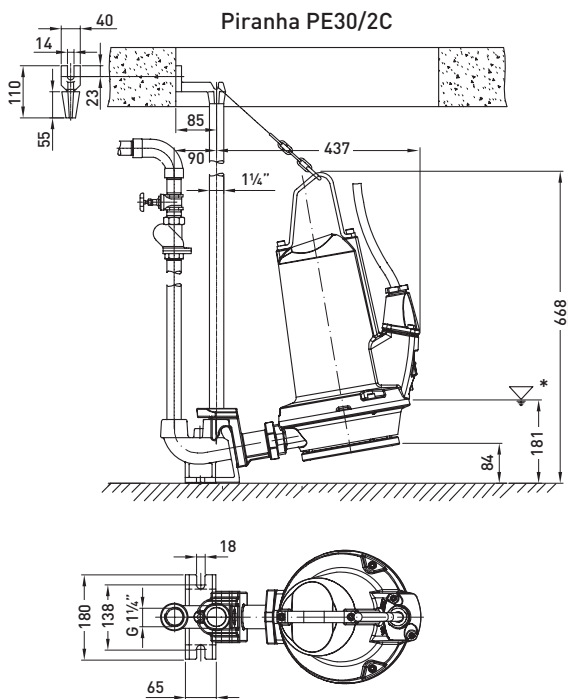
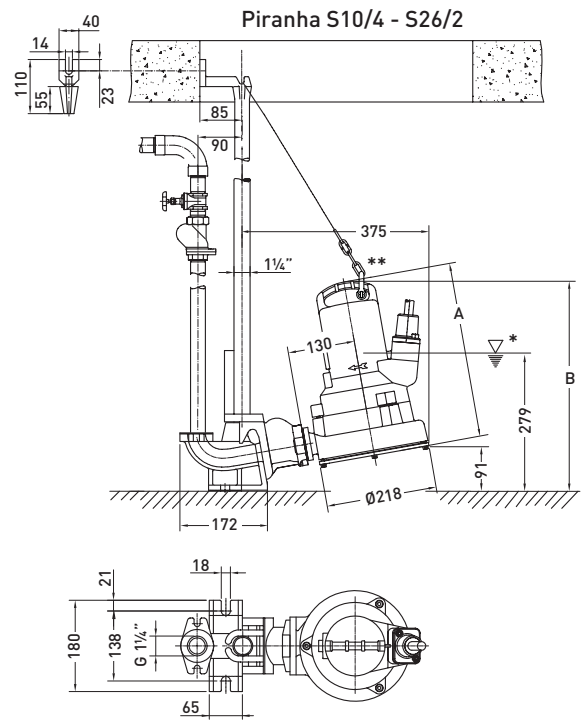
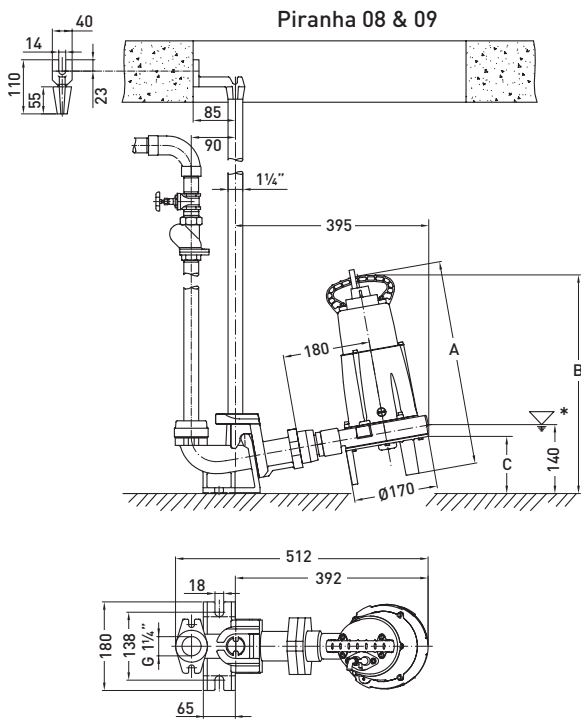

Piranha	A	B	C
08	420	445	117
09	445	470	108
S10/4 - S17/2	347	414	-
S21/2 & S26/2	360	427	-
PE55/2E - PE90/2E	-	774	-
PE110/2E	-	844	-

Piranha 08 - PE110/2E: Minimum sump opening $\varnothing 625$ mm
 Pedestal base secured using M10 masonry anchor bolts,
 drill hole size 14 mm
 * Lowest switch-off point for automatic operation

Piranha S10/4 - S26/2: ** To allow the pump to be lowered and fixed correctly to the pedestal,
 the shackle must be fixed to the handle at the point furthest
 from the guide rail.

Piranha PE55/2E - PE110/2E: Discharge line connection with threaded flange DN 50/2" PN16
 Discharge elbow supplied by customer
 *** Hexagon head wood screw 10 x 70 DIN 571 and dowel size 12

Accessories

	Description	Size	Part no.	Piranha	
Fixed installation with pedestal	Pedestal (EN-GJL-250) 90° cast bend	G 1¼"	62325007	08 & 09	
		G 1¼"	62320674	S10/4-S26/2	
		G 1¼"	62320676	PE30/2C	
		90° cast bend with built-in non-return valve	G 1¼"	62320536	S10/4-S26/2
			G 1¼"	62320538	PE30/2C
		without bend	DN 50/G2"	62320660	PE55/2E-110/2E
		Threaded Adaptor hexagon double nipple	G 1¼"	13770011	08 & 09
		Guide Rail (galvanized steel)	1¼" x 1 m	31380007	08-S26/2, PE30/2C
	1¼" x 2 m		31380008		
	1¼" x 3 m		31380009		
	1¼" x 4 m		31380010		
	1¼" x 5 m		31380011		
	Chain Kit (galvanized steel) including shackle	3 m	61265065	08-PE110/2E	
		4 m	61265093		
		6 m	61265069		
		7 m	61265096		
	Chain Kit (stainless steel) including shackle	3 m	61265081	08-PE110/2E	
		4 m	61265099		
		6 m	61265085		
		7 m	61265102		
Transportable applications	Threaded Flange Kit (EN-GJL-250) including discharge piece, gasket and bolts	G 1¼"	61180512	S10/4-PE30/2C	
	Ground Support Stand (St. 37) with fixing bolts		61900013 61900007	S10/4-S26/2 PE30/2C-110/2E	
	Fixed Coupling (brass) GEKA with external thread	G 1¼"	15020003	S10/4-PE30/2C	
	Hose Coupling with nozzle, outer dia. 34 mm	G 1¼"	15020018	S10/4-PE30/2C	
Horizontal (tank connection)	Pump with built-in flange on suction side	DN 150/PN 16 to DIN 2633	On request	S10/4-S26/2	
	Head Support (EN-GJL-250) with vibration damping		62665103	S10/4-S26/2	
General	Non-return Valve (EN-GJL-250) ball valve with internal thread	G1¼"	61400525	08-PE110/2E	
		G1½"	61400526		
		G2"	61400527		
	Shut-off Valve (brass) with internal thread	G1¼"	14040005	08-PE110/2E	
		G1½"	14040006		
		G2"	14040007		